

Refrigerated UPRIGHT Display Cabinet Test Report

Test Laboratory Name/Address

Laboratory of FROST TECH(Guangzhou) Refrigeration Facilities CO.,LTD.
Xiaowu Industrial Zone Dongchong Town,Nansha District,Guangzhou,
Guangdong Province,P.R.China.

Manufacturing Name/Address

FROST TECH(Guangzhou) Refrigeration Facilities CO.,LTD.
Xiaowu Industrial Zone Dongchong Town,Nansha District,Guangzhou,
Guangdong Province,P.R.China.

Brand Name	FROST TECH
Product	Refrigerated upright display cabinet
Description	The product covered by this report is a commercial used,cord connected refrigerated upright display cabinet.
Model(s)	GDT70C
Voltage/Frequency	220-240V,50Hz
Rating current	
Teststandard(s)orcriteria(s)	(EU)2019/2018 (EU)2019/2024 ENISO23953-2:2015
Conclusion	The results are in compliance with there requirements of the EC regulation 2019/2024. Energy efficiency class: C

Prepared by:He Jianjin

Photo 1 - Front view:



Name plate:

COMMERCIAL DISPLAY CABINET

Model	GDT70C
Voltage/Frequency	220-240/50Hz
Rating current	2.9A
Refrigerant	R452A - R448A - R404A (R290 Available)
Compressor	Tecumseh CAJ9510Z
Controller	LAE AD2-5C
Vesicant	Cyclopentane

Name:FROST TECH

Address: Xiaowu Industrial Zone Dongchong Town, Nansha, District,Guangzhou,Guangdong Province,

Photo 2 - Circuit diagram:

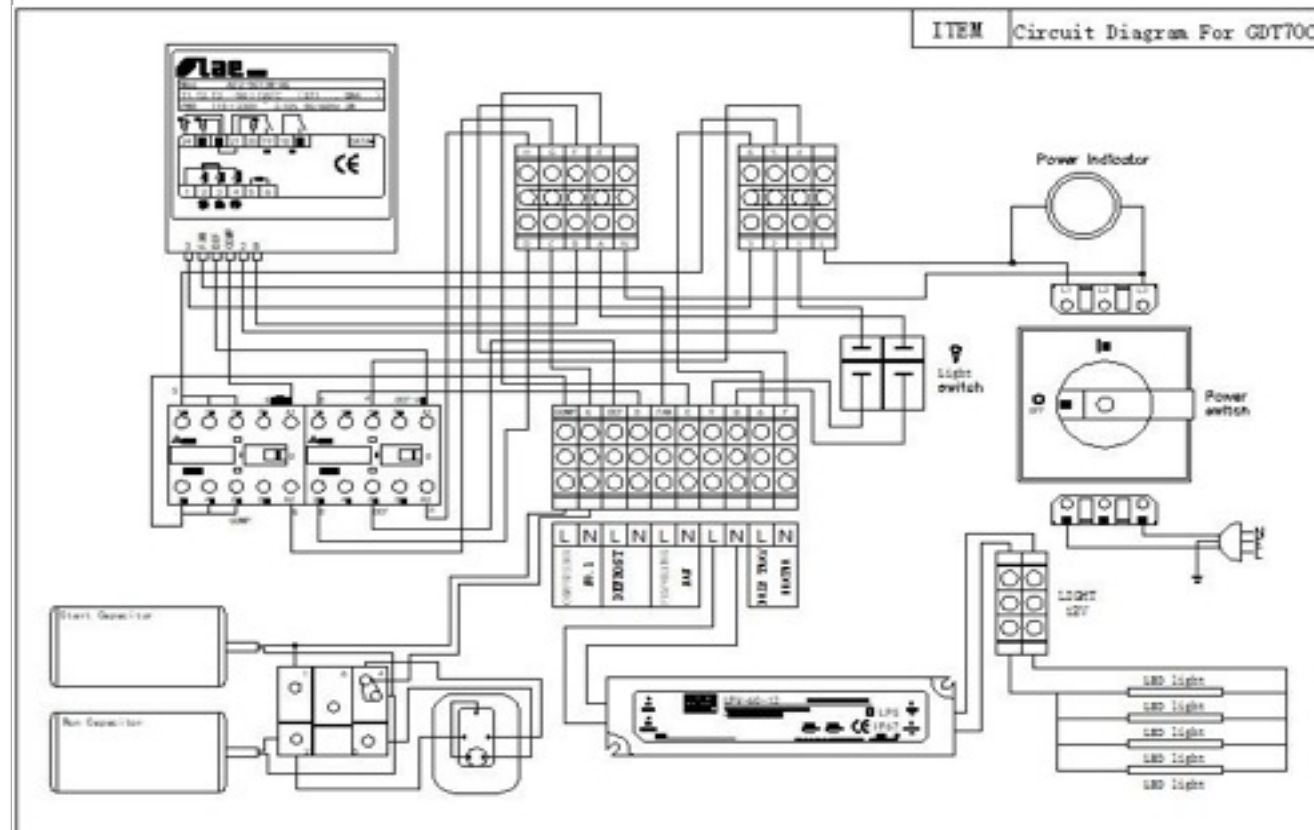

Product details:

Cabinet family code	VC4
Cabinet type	Integral
Model number of Unit Under Tested	GDT70C
Brand name	FROST TECH
Operating temperature(s)	Chilled
Category	Vertical and combined supermarket refrigerator cabinets
Energy efficiency class	D
Climate class	3
M PackageTemperatureClass	M2
Doors	2 Self-closing sliding glass doors
Shelves	5 adjustable shelves
Light	LED vertical light tube T8 16W
Refrigerant	R452A - R448A - R404A (R290 Available)
Charge of refrigerant(g)	350g
Over all dimensions(W*D*H)[mm]	700*700*1900

Performance parameter:

Highest temperature of the warmest M-package of the compartment(s) with chilled operating temperatures (°C)	
Lowest temperature of the coldest M-package of the compartment(s) with chilled operating temperatures, or the highest minimum temperature of all M-packages of the compartment(s) with chilled operating temperatures (°C)	+1°C

Critical Components:

Name	Manufacturer/trademark	Type/model	Technical data
Compressor	Tecumseh	CAJ9510Z	220-240V,50Hz
Controller	LAE	AD2-5C	220-240V,50Hz

Test Condition:

Dry Bulb	25±1°C
Relativehumidity	60±3%
Input Voltage	230V
InputFrequency	50Hz

Temperature and total display area Tests:

Temperature Class	Symbol	Temperature Test(°C)			Total display area test(m
		Temperature	Limit	Verdict	
M2	θah	6.5	≤7	Pass	2.3
	θb	1	≥-1	Pass	

Calculation for EEI and conclusion:

Total display area TDA(m	2.3
M	9.1
N	9.100
P	1.1
Y	2.3
C	1
Calculation formula	SAE:365*P*(M+N*Y)*C
Standard annual engery consumption SAE(Kwh/24h)	12057
Daily energy consumption Edaily (kWh/24h)	10.66
Annual energy consumption AE(kWh/a)	3893
Energy Efficiency Index EEI	32
Energy efficiency class	C
From 1 March 2021 :EEI<100,Ice-cream freezers:EEI<80	Pass
From 1 September 2023:EEI<80,Ice-cream freezers:EEI<50	Pass



Type	Length	Depth	Height	Nom. voltage/ frequency	Electricalfusing	Temperature range
GDT70C	700 mm	700 mm	1900 mm	230 V/50 Hz	13A,slow	0 ... +7 °C

