

## Refrigerated Display Cabinet Test Report

Test Laboratory Name/Address	
Laboratory of FROST TECH(Guangzhou) Refrigeration Facilities CO.,LTD.	
Xiaowu Industrial Zone Dongchong Town,Nansha District,Guangzhou, Guangdong Province,P.R.China.	
Manufacturing Name/Address	
FROST TECH(Guangzhou) Refrigeration Facilities CO.,LTD.	
Xiaowu Industrial Zone Dongchong Town,Nansha District,Guangzhou, Guangdong Province,P.R.China.	
Brand Name	FROST TECH
Product	Refrigerated display cabinet
Description	The product covered by this report is a commercial used, cord connected refrigerated display cabinet.
Model(s)	SLD75/120 C.C.
Voltage/Frequency	220-240V,50Hz
Rating current	7A
Drip tray Rating current	3A
Teststandard(s)orcriteria(s)	(EU)2019/2018 (EU)2019/2024 ENISO23953-2:2015
Conclusion	The results are in compliance with there requirements of the EC regulation 2019/2024.  Energy efficiency class: D

Prepared by:He Jianjin

Photo 1 - Front view:



Name plate:	
COMMERCIAL DISPLAY CABINET	
Model	SLD75/120 C.C.
Voltage/Frequency	220-240/50Hz
TOTAL Rating current	10A
Refrigerant	R452A-R448A-R404A (R290 Available)
Compressor	Tecumseh CAJ4517Z
Controller	LAE AD2-5C
Vesicant	CO2

Name:FROST TECH

Address:Xiaowu Industrial Zone Dongchong Town,Nansha District,Guangzhou,Guangdong Province,P.R.China.

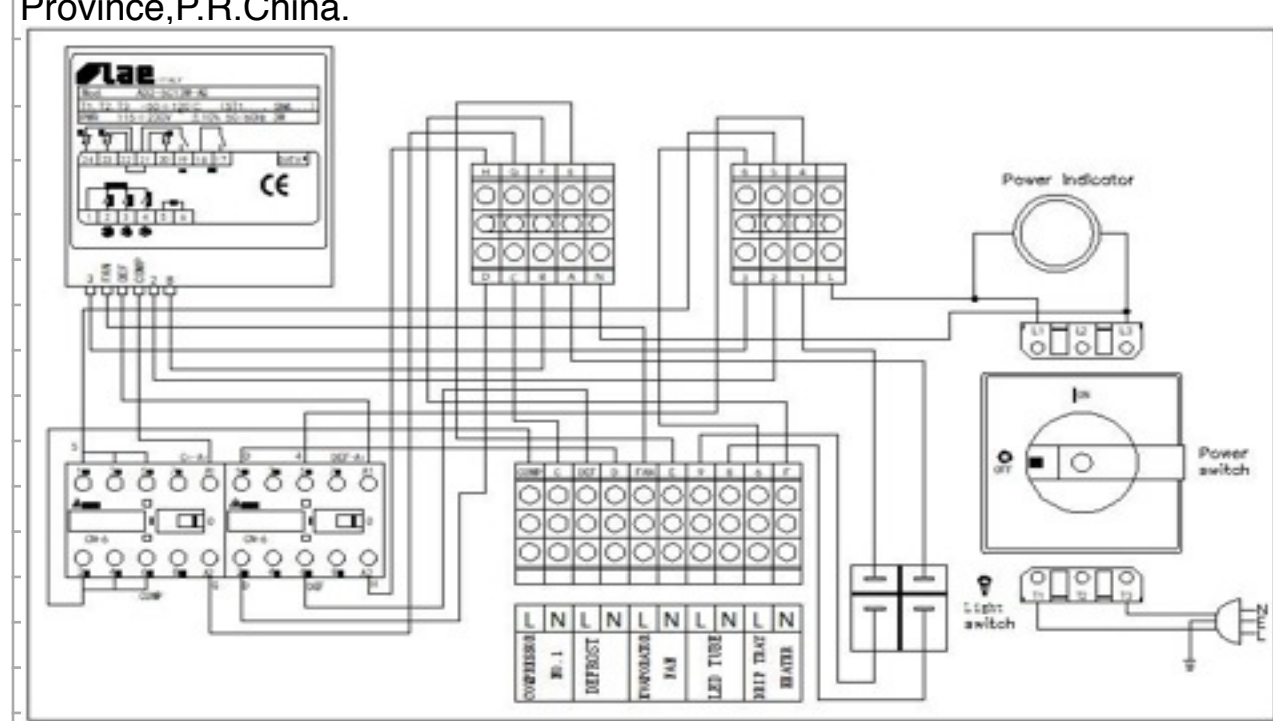

Product details:	
Cabinet family code	VC2
Cabinet type	Integral
Model number of Unit Under Tested	SLD75/120 C.C.
Brand name	FROST TECH
Operating temperature(s)	Chilled
Category	Vertical and combined supermarket refrigerator cabinets
Energy efficiency class	D
Climate class	3
M Package TemperatureClass	M2
Doors	N/A
Shelves	3 Toughened glass shelves
Light	LED tube
Refrigerant	R452A-R448A-R404A (R290 Available)
Charge of refrigerant(g)	1050
Over all dimensions(W*D*H)[mm]	1200*775*1515

Performance parameter:	
Highest temperature of the warmest M-package of the compartment(s) with chilled operating temperatures (°C)	+7
Lowest temperature of the coldest M-package of the compartment(s) with chilled operating temperatures, or the highest minimum temperature of all M-packages of the compartment(s) with chilled operating temperatures (°C)	-1

Critical Components:			
Name	Manufacturer/trademark	Type/model	Technical data
Compressor	TECUMSEH	CAJ4517Z	220-240V,50Hz
Controller	LAE	AD2-5C	220-240V,50Hz

Test Condition:	
Dry Bulb	25±1°C
Relativehumidity	60±3%
Input Voltage	230V
InputFrequency	50Hz

Temperature and total display area Tests:					
Temperature Class	Symbol	Temperature Test(°C)			Total display area test(m
		Temperature	Limit	Verdict	
M2	θah	6.7	≤7	Pass	2
	θb	1.2	≥-1	Pass	

Calculation for EEI and conclusion:	
Total display area TDA(m	2
M	9.1
N	9.100
P	1.1
Y	2
C	1
Calculation formula	SAE:365*P*(M+N*Y)*C
STANDARD annual engery consumption SAE(Kwh/24h)	10960.95
Daily energy consumption Edaily (kWh/24h)	14.67
Annual energy consumption AE(kWh/a)	5390
Energy Efficiency Index EEI	49
Energy efficiency class	D
From 1 March 2021:EEI<100,Ice-cream freezers:EEI<80	Pass
From 1 September 2023:EEI<80,Ice-cream freezers:EEI<50	Pass



